

# Welcome Back



# To Willows!



**Its been a while since we've seen each other and we are looking forward to welcoming you back.**

**A lot has changed since COVID 19 escaped into the world.**

**Here in BC we have done a really good job at staying safe and we plan to keep it that way!**

How do you feel about returning to school? Some students are nervous, some are excited, some are unsure, others can hardly wait! No matter how you feel, its ok. We are here for you.



COVID 19 is contagious, that means it can spread from person to person. But if we follow the safety rules, we don't have to worry, we'll stay safe while learning and having fun.





It will not be the same as it was before COVID 19.  
There will be around 8 children in each classroom  
for the first while.



It won't be the same, but it will still be fun!





One of the many ways to keep you safe is using arrows and dots showing you which ways to walk and how far apart!



There will be outside learning and play time at a distance from each other. We won't be able to play with the same toys or have physical contact but we can still enjoy our enormous outside space.





One of the best ways to stay safe is to stay physically apart.



shutterstock.com + 1672818163



Be close at heart but physically apart!



We'll still eat snacks and lunch at school and everything you bring in must be taken out. No garbage left behind.



Wash you hands, wash your hands, wash your hands!  
The corona virus does not like soap and water.

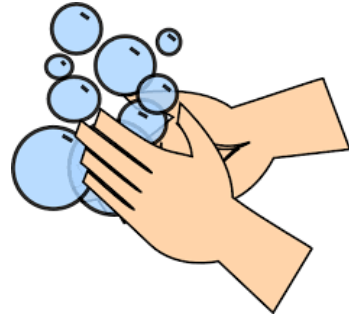



Step 1:  
Wet your hands.



Step 2:  
Add soap!

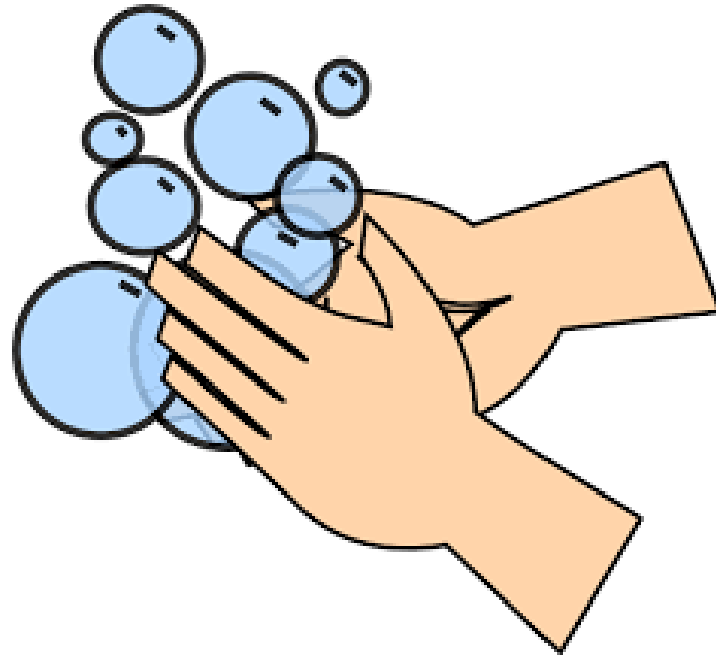

Step 3 : Scrub your hands. Scrub the palms, scrub the backs, scrubs in between your fingers and your thumbs and don't forget your finger nails. Scrub for 20 seconds..... that's a long time!



Step 4:

Rinse the soap off and say goodbye to the germs!





Step 5:  
Use a paper towel to dry your hands.

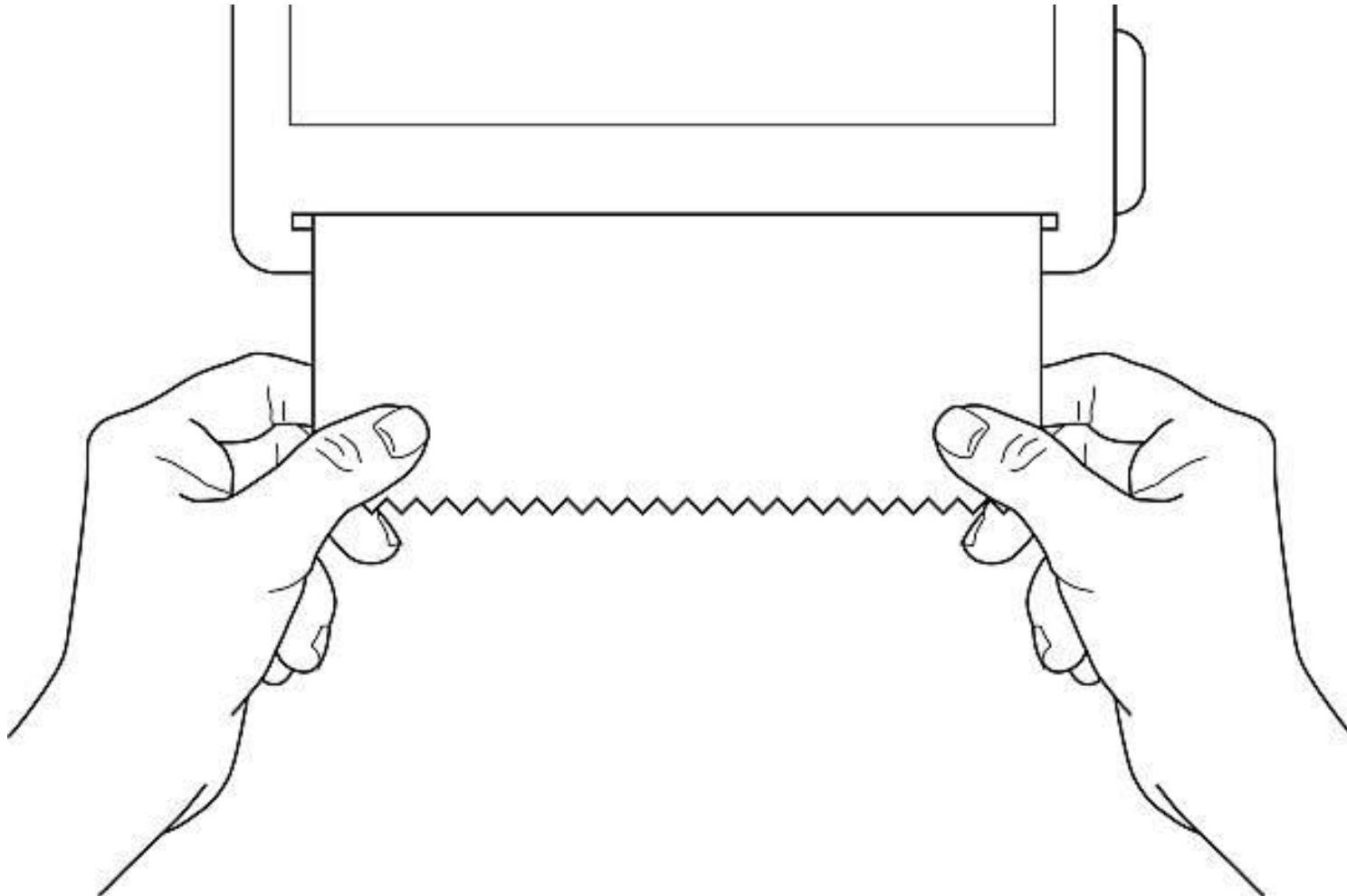

Step 6:  
Use the paper towel to shut off the tap.



Step 7:  
Throw the paper towel away!



Voila!! Your hands are germ free...for now😊





If you don't have soap and water, you can use hand sanitizer.



Teachers and Educational Assistants will be here to help make learning fun! It may not be your regular teacher and Ed. A but all Willows staff are here for you!



Students will line up outside 6 feet apart and follow the arrows to their classroom.



You have probably heard grown ups talk about social or physical distancing. This means making a bigger personal bubble so we don't touch others or get close enough to spread germs.

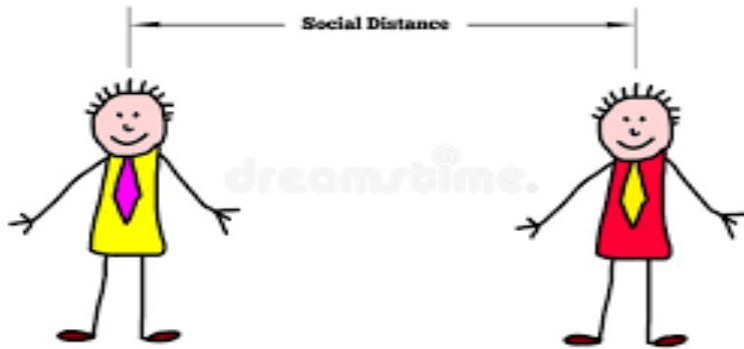

VectorStock®

VectorStock.com/30426830

How big should your personal bubble be at school?  
Spread your arms out and spin around like a  
helicopter, if you come close to others  
you are too close.

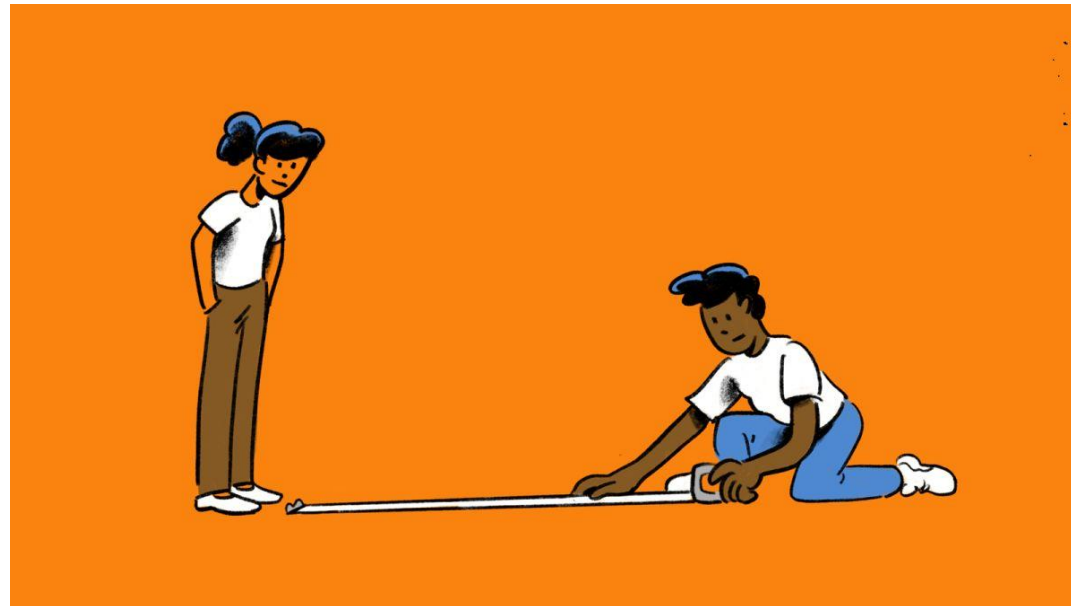
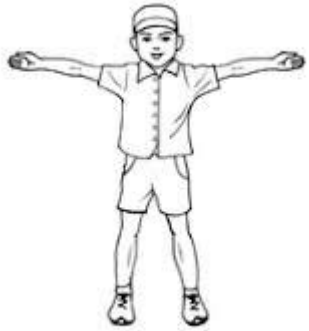

This is nothing new....after you use the  
WASH YOUR HANDS! Remember germs  
do not like soap and water.



This is new.... A limited number of students in the bathroom at a time!

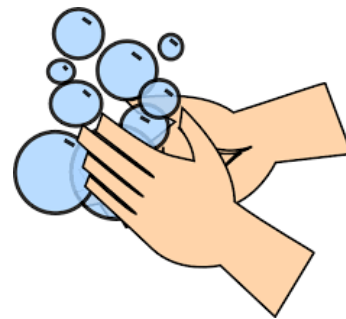



If you sneeze or cough, please sneeze or cough in your elbow. If you use a Kleenex, throw it away and after you cough or sneeze or blow your nose.....wash your hands!

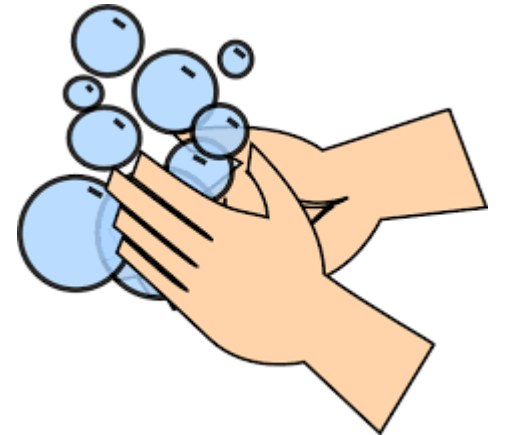

Whew, that's a lot of safety! But we can do this together! It isn't forever, its just for now. Smiles will replace hugs and remember fun is contagious too 😊



By Mrs. Melinda

